

Local Oscillators

7.1 Overview

For a description of the overall plan for the local oscillator subsystem, please see section 4.4 and Figure 4.1 of this book. This chapter gives additional details, some of which apply to the ALMA array as well as to the test interferometer.

7.2 Reference Distribution

John Battle, 2000-02-15

7.2.1 Low frequency reference generator

The Low Frequency Reference Transmitter in the central electronics building will combine the 20 Hz and 25 MHz reference signals and intensity modulate a laser signal which is then transmitted over an uncompensated fiber link to the two antennas of the test interferometer antennas. The unit will consist of a laser diode and an MZ modulator and appropriate temperature control and modulation control circuitry. There will be a microprocessor which will perform control tasks as well as communicating status over the Monitor/Control CAN network.

Specifications - Low Frequency Reference Transmitter

Input Signals:

Reference freq	25.0 MHz @ +10 dBm, 50 ohms
Reference freq	20.0 Hz @ 1 volt, high impedance

Output Signals:

Laser two way split

7.2.2 Reference receiver

The purpose of the Reference Receiver is to receive both the low-frequency laser reference and the dual laser reference signals and process them in order to produce the fundamental LO reference signals at the antenna. The dual laser signal is then passed on to the LO drivers where the photonic reference first LO signal is generated. The dual laser signal is also frequency shifted by 25 MHz in an acousto-optic modulator and returned to the central electronics building LO for use in the path length correction system. The acousto-optic modulator is a true single sideband modulator and its output consists of only the shifted frequency.

The Reference Receiver unit will include a monitor and control interface which will provide self test and status information to the central control computer.

In order to establish the correct relative phase of the various reference signals generated in this

module, a circuit called an "Ambiguity Resolver" is used to synchronize the zero crossings of each signal with the next higher frequency's zero crossings. Detail design and specifications for this device have yet to be worked out.

Specifications - Reference Receiver

Inputs:

High reference, optical wavelength 1550 nm (intensity TBD)

Low Reference, optical wavelength 1550 nm (intensity TBD)

Outputs:

Reference frequencies 2.0 GHz @ +20 dBm, 50 Ohms

125.0MHz @ +20 dBm, 50 Ohms

100.0 MHz @ +20 dBm, 50 Ohms

25.0 MHz @ +20 dBm, 50 Ohms

20 Hz @ 1 volt RMS, High Z

7.3 First Local Oscillator

A simplified schematic of the first local oscillator consisting of synthesizer, distribution system, a high-frequency photomixer, and phase-locked oscillator is shown in Fig. 7.1. The reference is generated photonically at the central building and distributed to each antenna by optical fiber. Three LO drivers are needed to cover the receiving bands of the evaluation receivers (see Chapter 6 of this book). An LO driver includes a Gunn oscillator or a YIG-tuned oscillator. The 211-275 GHz receiver will incorporate a tripler. The oscillators in these LO drivers will be phase locked to the photonic reference at the receiver. Coherence between the receivers at each antenna is maintained by a continuous round trip correction of the fiber optic distribution to the antennas. The round trip correction is achieved by means of an optical interferometer that keeps the number of optical wavelengths of a master laser constant to within an optical fringe.

7.3.1 Laser Synthesizer

Bill Shillue, 2000-02-15

Fig. 4-1 sheet 2 is a schematic of the laser synthesizer. The master laser is split and a pair of slave lasers are in turn phase locked to the master laser in two laser synthesizer modules, one for each antenna. These are inside the central station, and the laser synthesizer includes frequency references from the central reference generator module and an X-band microwave synthesizer. The laser synthesizer employs light from two lasers, tuning the second laser to a fixed offset from the first laser. The two wavelengths of light are then sent along the fiber where they are converted to the appropriate millimeter-wave reference by a photomixer.

A master laser and a slave laser are phase locked to each other at a difference frequency of from 27-122 GHz by use of two microwave references. The master laser is input to a device called an optical comb generator. The optical comb generator uses a resonant modulation technique to phase modulate the laser at extremely high modulation index. This creates a spectrum of "comb-lines" equally spaced from the carrier by the modulation frequency. A high-Q optical filter then selects the desired comb-line. The end result is that the master laser frequency has

CENTRAL BUILDING

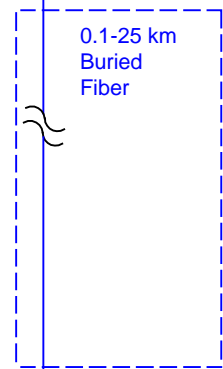
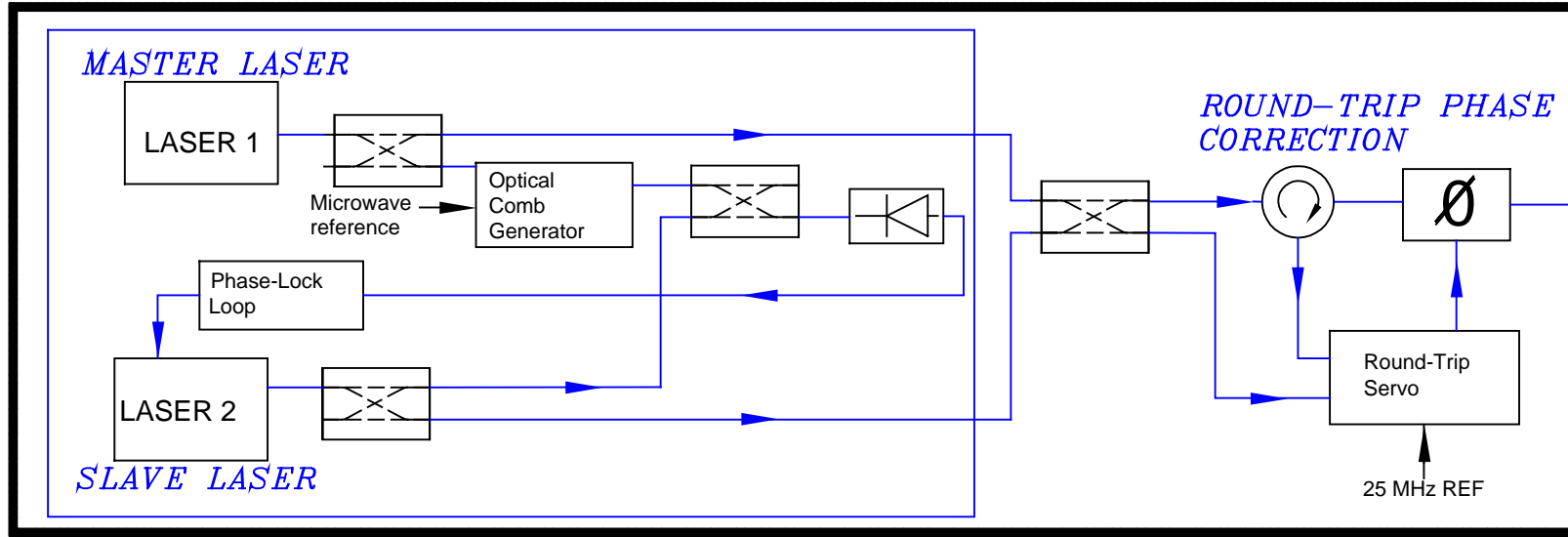

ANTENNA RECEIVER CABIN

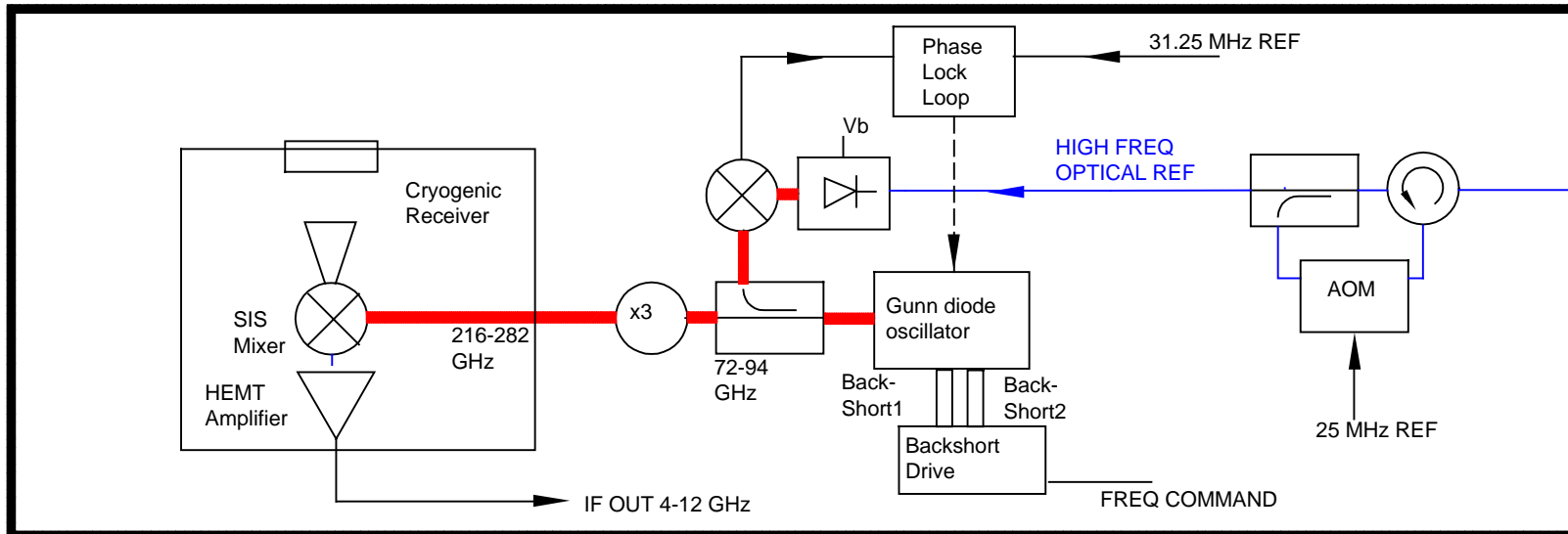

Only band 6 is shown for clarity

Figure 7.1: Simplified block diagram of first LO chain.

been shifted by the modulation frequency times a fixed integer value. The slave laser is then offset-locked to this shifted frequency.

For a more complete description of the technique for phase locking two lasers and some typical phase noise results, see

http://www.tuc.nrao.edu/~demerson/project_book/chap7/chap7.1/chap7.1.html.

For a more complete description of the details of the optical comb generator, see

<http://www.mma.nrao.edu/memos/html-memos/mma200/memo200.html>.

7.3.2 Round Trip Correction

Bill Shillue, 2000-02-15

The first local oscillator must be coherent between both of the antennas in the test interferometer. Ideally, the phase error associated with the distribution of the first LO reference should be a negligible contributor to the overall phase noise. The idea of stabilizing the fiber distribution to an optical fringe came about because it was realized that for the ALMA array, the coherent distribution must be stable to within a small fraction of the shortest observing wavelength, which is 350 microns. By tracking with an optical interferometer, the overall path length error must be smaller than half of the optical wavelength, or 0.78 microns.

The technique of round trip correction by optical interferometer is described in some detail in

http://www.tuc.nrao.edu/~demerson/project_book/chap8/chap8.3/chap8.3.html and in

<http://www.mma.nrao.edu/memos/html-memos/alma267/memo267.pdf>.

The difference frequency is transmitted to each antenna by optical fiber. The fiber first goes to a module called the reference receiver. At the reference receiver a small portion of the light is tapped off and frequency shifted, then sent back to the central building thus completing the round-trip

The technique of round trip correction relies upon the exceptional linewidth of the best commercially available 1.55 micron band lasers, which are less than 5 kHz. This gives a coherence length of greater than 50 km, allowing the optical interferometer to operate at the longest baselines being considered for ALMA. Also, the phase correction requires a high degree of absolute stability of the master laser. The absolute stability required is proportional to the (distance * frequency difference), and for the most difficult case of 950 GHz over 25 km, a stability of better than 100kHz will be required. Stability better than this can be obtained from commercially available lasers. For the ALMA array a master laser combining exceptional linewidth with this frequency stability will be required. However, for the test interferometer the distance is quite small, less than 1 km, and the maximum frequency difference after multiplication is 279 GHz. The construction of the fiber line corrector for the test interferometer will be combined with developing a technique to stabilize the absolute frequency of the master laser to the degree required for the ALMA array.

The most recent test result of a lab-based round trip system uses a 25 GHz beatnote (frequency difference and a 25 km spool of fiber, for a 50 km round-trip. Fig. 7.2 shows the result for a two-

minute tracking cycle. The top trace shows the phase drift. The corrector tracks for the first minute, and the phase drift is less than ten degrees. With the corrector off, the phase drifts greater than 50 degrees in the next minute. The bottom plot shows the amount of fiber stretch that is used to compensate for the phase drift. The small drift in the tracking state is due to frequency drift of the master laser. As mentioned, stabilization of the laser to the degree that will be required is quite common.

25 GHZ 25 KM ROUND TRIP PHASE
 CORRECTOR ON/OFF
 Date: 12-14-99 Time: 11:36:00 AM

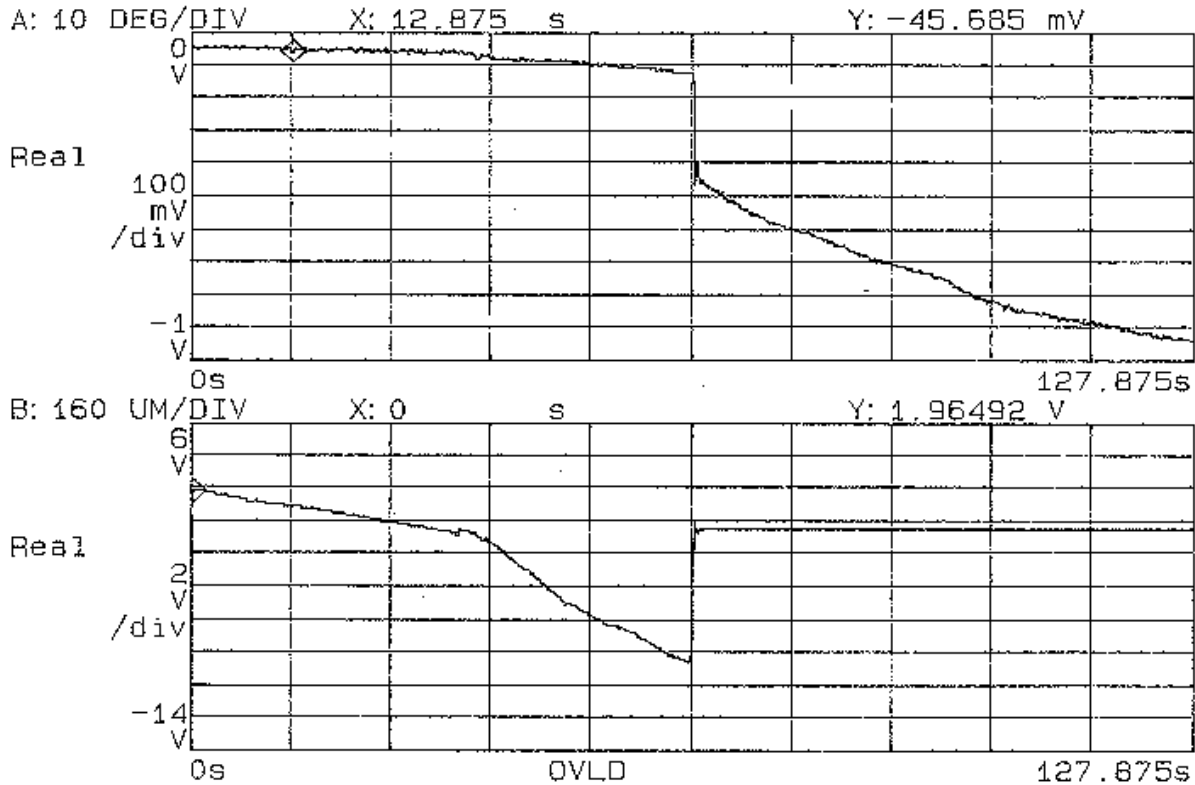

Figure 7.2: Round Trip Phase Correction with 25 GHz Beatnote and 25 km fiber. Top trace is the phase difference between the beatnotes at opposite ends of fiber. The bottom trace is the position of the fiber line stretcher with the scale given in microns. The line corrector was turned off halfway through the test.

7.3.3 Drivers and Multiplier

7.3.3.1 Photomixers

For the test interferometer, photomixer devices spanning 27-122 GHz in discrete bands will be required. A minimum output power of one microwatt is required, although ten

microwatts is expected. Many details of the design and state-of-the-art of both commercial and research-grade high frequency photomixers is given in http://www.tuc.nrao.edu/~demerson/project_book/chap7/chap7.1/chap7.1.html. That discussion assumes that a direct photonic approach is being used, but for the photonic reference, all of the same considerations apply, but the output power specification is relaxed.

An NRAO test of a commercial photodetector (NTT KEPD2525VPG) resulted in measured output powers of 9 microwatts at 78 GHz and 0.2 microwatts at 110 GHz. However, that particular detector had a coaxial output connector that was overmoded above 60 GHz and also required a bias tee on its output. The only available bias tee also had coaxial connectors, so it was estimated that at least 10 dB more and perhaps higher output power would be available from such a device if the bias and output circuit were properly configured. This type of device can be used for the 31-45 GHz HFET receiver frequency reference, locking a 27-33 GHz YIG tuned oscillator. For the higher frequency bands, a photomixer with a waveguide output and integrated bias tee would be more practical.

A photomixer manufacturer has been found that sells a suitable device in chip form (<http://www.u2t.de>). These chips are inexpensive, high current (6 mA), have an integrated bias tee, and have been used above 100 GHz. It is our intention to characterize the device in chip form, and then integrate the device with a transition to fundamental mode waveguide.

7.3.3.2 Oscillators Graham Moorey
<to be written>

7.3.3.3 Tripler (72-90 to 217-269 Ghz) Graham Moorey
<to be written>

7.3.4 Controller and PLL Graham Moorey
<to be written>

7.4 Second LO Synthesizers John Battle, 2000-02-15

The second LO synthesizers provide the local oscillator source for the second mixers used to demultiplex the sideband IF into four 2 GHz channels which are arbitrarily located relative to the input band. Four of these synthesizers are required for each antenna and each must be independently tunable in 62.5 GHz steps. Each will include an independently tunable Fringe Rate Generator which provides a frequency offset tunable in one milli-Hertz steps over a tuning range of approximately 1 MHz. The second synthesizer must return to the same absolute phase when tuned away from a frequency and then returned to the same frequency at a later time. The output power required must be at least +10 dBm over the entire frequency tuning range of 6.000 GHz to 10.000 GHz.

Figure 7.3 is a preliminary block diagram of the 2nd Synthesizer. The output is derived from a 125 MHz reference signal which is transmitted over the fiber. The output of a 125 MHz

harmonic generator is mixed with the output of the YIG to produce a 31.25 MHz IF signal whenever the YIG is tuned to $31.25 \times (2n+1)$ MHz. The output of the 31.25 MHz IF is phase detected with the 31.25 MHz output from the fringe generator and the output of this phase detector is used to close the loop around the YIG oscillator. The output of the YIG is pre-scaled so that the microprocessor can be used to measure the approximate frequency of the YIG, allowing the microprocessor to "coarse tune" to the desired frequency. The phase-lock-loop is then closed and allowed to lock. Since the counters are not actually part of the loop, none of their phase noise contributes to the final signal.

Specifications - Second LO Synthesizer

Input Signals

Reference freq, high	125.0 MHz @ 0 dBm, 50 ohms
Reference freq, low	20 Hz @ 1.0 volts RMS, high z

Output Signals

Tuning Range	6.0 - 10.0 GHz
Tuning Step Size	62.5 MHz
Power Output:	+8 dBm to +12 dBm adjustable
Fine Tuning Range	+/- 1.0 MHz Min
Fine Tuning Steps	0.001 Hz Max
Phase Steps	0.1 Degree Max

M/C Bus: High Speed Controller Area Network (CAN)

Control Functions:

- Set Main Tuning Frequency
- Set Fine Tuning Frequency
- Set Phase
- Set Power Output
- Upload Frequency Parameters
- Upload Phase Parameters
- Output On/Off
- Self Test

Monitor Functions:

- Power Supplies Ready
- Output Present
- Output Power Level
- Coarse Tuning Frequency
- PLL Locked
- Module Temperature
- Start Programs

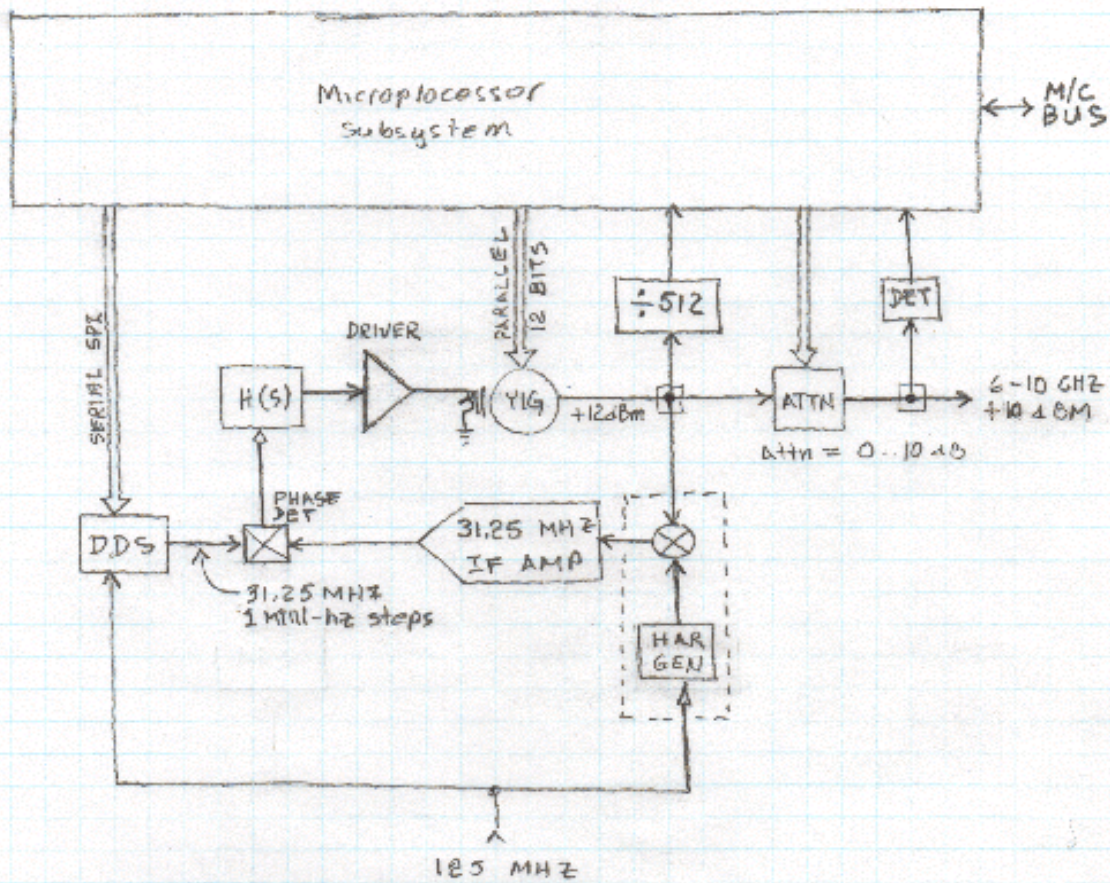

Figure I. The Second Synthesizer

Figure 7.3: Second LO synthesizer block diagram.