

LOCAL OSCILLATORS: MULTIPLIER SYSTEM

*Richard Bradley
Last revised September 24, 1998*

Revision History:

9/24/98: Added chapter number to section numbers. Placed specifications in table format. Added milestone summary.

Summary

This section describes a Local Oscillator (LO) system using modern multiplier chains. The conventional approach to generating local oscillator (LO) power for millimeter and submillimeter wave heterodyne mixers is to generate power at a lower frequency using a suitable phase-locked source, and to convert this power to the desired commensurate frequency using a nonlinear diode such as a varactor in a frequency multiplier circuit. Although useful for single-dish telescope receiver systems, the conventional approach, using current state-of-the-art components, is highly impractical for large array-type radio telescopes for which manageable cost and high reliability are important factors. A summary of the MMA LO specifications, current state-of-the-art, and development plans are presented. See [1] for more information.

The goals for the design and development phase are to develop several frequency multipliers; to develop source driver chains consisting of YIG oscillator, multipliers, and power amplifiers; to characterize the noise properties of all the above; and to provide a prototype complete LO chain for the 230 GHz band.

Table 7.2.1 LO multiplier system specifications

Item	Specification
Power output	~100 microwatts per receiver
Amplitude noise	1 K per microwatt
Phase noise	3 degrees rms for $t > 1$ second
Frequency range	As required by receivers
System compatibility	Phase lock to reference signal; Track fringe rotation; Frequency monitor and control; Power leveling
General considerations	No mechanical tuning; High reliability; Minimal cost

Table 7.2.2 Principal milestones for LO multiplier work during D&D phase

PDR	11/15/98
230 GHz doubler demonstration	12/31/98
660 GHz tripler demonstration	12/31/99
CDR	3/31/00
Deliver 230 GHz LO for prototype receiver	1/31/01

7.2.1 Frequency Requirements

A proposed band plan for the MMA is shown in Table 7.2.3. The first three columns indicate the type of receiver, either HFET for the lower frequencies or SIS for the higher frequencies, the RF band, and the RF band-delimiting frequency ratio defined as f_{max}/f_{min} for each band. The highest frequency band is a future possibility and is not planned to be implemented as part of the initial construction. Assuming an IF band from 4-12 GHz, columns four and five show the LO tuning range required and the LO band-delimiting frequency ratio defined as f_{max}/f_{min} for each LO range. A prime feature of this plan is that all LO frequencies above 60 GHz can be derived from two phase-locked sources: #1 covering the range 60-90 GHz, and #2 covering 80-120 GHz. It should be noted that since the noise of SIS mixers may increase with IF frequency, the sensitivity of the radiometer for spectral line observations may be improved somewhat if only the lower portion of the IF band is used. The LO tuning range required to achieve optimum sensitivity may therefore be greater than that shown in the Table 7.2.3.

For other possible frequency plans (see MMA Memo 213), similar plans to the one discussed here could be generated. In general, the narrower the frequency coverage of any receiver, the easier it is to provide LO power.

Table 7.2.3 Possible frequency plan with complete coverage [1]

Receiver type	Frequency Range (GHz)	Frequency ratio	LO range (GHz)	LO frequency ratio
HFET	33-50	1.52	55-64	1.16
HFET/SIS	68-90	1.32	90-104	1.16
HFET/SIS	90-116	1.29	76-94	1.24
SIS	125-175	1.40	137-163	1.19
SIS	245-320	1.31	257-308	1.20
SIS	320-416	1.30	332-404	1.22
SIS	416-510	1.23	428-498	1.16
SIS	602-720	1.20	614-708	1.15
SIS (future)	787-950	1.21	799-938	1.17

7.2.2 Power Requirements

A specification for the LO power level is derived from the pump power required by the SIS mixers which is approximately 1 microwatt. In the worst-case scenario where only single-ended SIS mixers are used, a waveguide or quasi-optical LO coupler, having a coupling factor of -20 dB, will be required to combine the LO with the RF signal. As a result, the amount of LO power required at the input of the receiver will be approximately 100 microwatts. An estimate of frequency conversion efficiencies that form realistic yet challenging goals for new broadband, fixed-tuned, planar frequency multiplier designs is given in Table 7.2.4. The first three columns give the LO tuning range from Table 7.2.3, the driving source tuning range, and the multipliers needed. Columns four and five give the multiplier efficiency and output power for a driving power of 50 mW.

It is proposed that each receiver of a dual-polarization system be equipped with a separate multiplier chain that is driven by a common source. The minimum required output from the single phase-locked source will therefore be 100 mW. Such pairing of the multiplier chains with the receivers has the following benefits: 1) switching of the LO source at 100 GHz rather than at the higher LO output frequency minimizes the losses associated with the long waveguide runs inside the dewar, the vacuum window, and the waveguide switch, 2) multiplier chains could be tied to the cryogenic refrigeration system to improve conversion efficiency and increase the varactor lifetime, and 3) an LO leveling circuit, perhaps using the SIS mixer current in a servo loop while adjusting the bias current on the frequency multipliers, could be incorporated into each multiplier chain. Given the expected performance of the multipliers, the available dynamic range is shown in column six of Table 2. This dynamic range can be increased substantially if balanced mixers are used [2], since the RF and LO ports will then be separated, eliminating the need for the -20 dB LO coupler.

Table 7.2.4 Estimated efficiencies required for multiplier chains (50 mW drive level assumed).

LO tuning range (GHz)	Drive tuning (GHz)	Multiplication factor	Conversion Efficiency (%)	Output power (mW)	Power leveler dynamic range (dB)
137-163	68-82	X2	30	15	22
187-233	93-117	X2	20	10	20
257-308	85-103	X3	5	2.5	14
332-404	83-101	X2, X2	20,10	1	10
428-498	71-83	X2, X3	30, 3	0.45	7
614-708	102-118	X2, X3	20, 3	0.3	5
799-308	99-118	X2, X2, X2	30, 15, 5	0.1	0

7.2.3 Amplitude Noise

The specification for LO amplitude noise is to meet an acceptable value for the gaussian noise that will be added to the front-end noise of the SIS receiver. The contribution of LO noise to the HFET front-ends will be negligible. The mixer LO noise manifests itself as noise sidebands associated with the CW source, but far enough away from it that the noise will ultimately appear in the RF passband of the receiver. It has been suggested that the LO amplitude noise contribution to the noise temperature of a single-ended SIS mixer be limited to one degree Kelvin, and with a typical LO pump power of 1 microwatt per mixer, a specification of 1 Kelvin per microwatt is therefore defined. A relatively low-Q bandpass filter, centered about the signal frequency, can be used to reduce this noise if needed. If balanced mixers are used, the specifications for the filter can be relaxed in proportion to the LO isolation that is provided, typically on the order of 10 to 20 dB, or perhaps eliminated entirely.

7.2.4 Phase Noise

The dominant contributor to the phase fluctuations encountered by the MMA will be atmospheric fluctuations along the line of sight of the instrument. Two distinct methods [3] are currently being considered for phase calibration: 1) Fast Phase Calibration (FPC) and 2) Radiometer Phase Correction (RPC). Based upon the requirements of these proposed phase calibration methods, as well as the need to use holography to measure the surface features to the desired accuracy of better than 8 microns (wavelength/100), the resulting phase stability specification for the electronics, as defined by the MDC Phase Calibration Working Group, is 3 degrees over time scales greater than 1 second. This specification will be used as a guideline for MMA LO development. However, specifications for allowable phase fluctuations on time scales

shorter than one second have not yet been defined. Integration-and-dump times, associated primarily with mosaicing operations, will be the defining factor for this specification.

7.2.5 Reliability and Cost

Reliability is an important issue not only because of the number of components required but also due to the remoteness of the observing site [4]. Reliability can be greatly enhanced by using all-electronic tuning and by replacing the fragile point contact varactor with the more rugged planar varactor. Due to the relatively large current densities in varactors, anode temperatures can reach well over 100 degrees C above ambient, thus compromising the long- term lifetime. The lifetime can be increased indefinitely through the use of cryogenic cooling which is typical in modern receivers and therefore should not increase the cost of the LO. The cost of building frequency multipliers is rather large due to the current complexity of the micro fabrication required. This cost can be reduced substantially at the circuit design stage by using monolithic (MMIC) technology [5], minimizing the machining operations required, and reducing the need for close tolerances during machining steps so that efficient duplication can be achieved. Finally, the higher-frequency multipliers should be designed as cascaded components of doublers and triplers for interchangeability.

7.2.6 State of the Art

In order to improve upon reliability and decrease cost, the limitations of the two basic components in the current LO system, namely the oscillator and the frequency multiplier, must be carefully examined. For the power source, the mainstay is the Gunn-effect oscillator which has been used successfully for many years because of its adequate output power, inherently low amplitude noise characteristics, and electronic fine tuning making it well suited for phase-locked circuitry. However, for large array applications, its usefulness is somewhat compromised since the coarse tuning is accomplished through mechanical adjustment of a high-Q resonant cavity. It is an expensive task to make this mechanical adjustment automated, accurate, repeatable, and reliable. Also, such cavity systems can suffer from unwanted moding which results in narrow frequency bands in which the output power can drop to very low levels. The mechanical tuning is limited in range as well, and, hence, several Gunn oscillators are needed to cover a given waveguide band. The maximum operating frequency of second harmonic Gunn oscillators is about 150 GHz, and so to reach millimeter and submillimeter wavelengths, frequency multipliers are required. State-of-the-art multipliers are limited in performance because of several factors, including: narrow instantaneous bandwidth requiring mechanically-adjustable tuning structures that may reduce reliability, low conversion efficiency leading to difficulties in power distribution, use of point-contacted varactors which are mechanically fragile structures, and intricate mechanical details making component assembly rather difficult. Overcoming these limitations is essential if conventional LO systems are to be made practical for the MMA.

All-electronic LO tuning has the advantage of improving reliability for array systems at a modest cost. The most useful all-electronic power source up to 50 GHz is the Yttrium-Iron-Garnet (YIG) tuned FET oscillator (YTO). A YTO can be tuned over a very broad band and it can easily be phase-locked to a reference source. A chain consisting of a YTO, followed by

wideband, fixed-tuned frequency multipliers and low noise power amplifiers, forms a viable alternative to a Gunn oscillator chain. Wideband monolithic HFET power amplifiers are becoming increasingly more common up to 100 GHz, primarily due to current military and commercial demands for systems operating in this frequency range. However, the development of wideband frequency multiplier technology has lagged behind in development. Advances in this area will determine the success of future YTO-based millimeter and submillimeter wave LO systems.

Over the past few years, the single most important factor influencing future frequency multiplier development has been the advent of versatile computer-aided design packages enabling the design engineer to analyze complex electromagnetic structures, create and simulate detailed equivalent circuit models, and predict semiconductor transport properties, all to a high degree of accuracy. For the first time, the nonlinear dynamics of the varactor, the electrical properties of the semiconductor package, and the embedding circuitry of the multiplier can be analyzed together as a complete frequency multiplier circuit. Very successful millimeter wavelength multiplier circuits have recently been developed by Porterfield et al. [6] and Erickson [7] based on calculations using modern computer-aided design tools. Upon applying such tools, one begins to understand the reasons behind the limitations of existing multiplier designs, thus opening the door to exploring new approaches and techniques never before possible in order to meet the stringent demands placed on the LO system by the MMA specifications.

7.2.7 Development Plan

The conventional LO development plan is divided into four technical development areas:

1. Frequency multipliers using discrete planar varactors,
2. Frequency multipliers using monolithic circuitry,
3. LO phase-locked source development and evaluation, and
4. Functional prototype LO development.

The first deals with broad-band, fixed-tuned frequency doublers used to extend the phase-locked loop LO system to cover the 137-163 GHz and 187-233 GHz bands. Frequency doublers for these bands will be based on the highly successful 40/80 GHz design [6] which uses a balanced planar varactor chip from the Semiconductor Device Laboratory of the University of Virginia. The measured results are shown in Fig. 7.2.1 for room temperature operation. The peak efficiency increased to more than 60 percent upon cooling the doubler block to 20 K. There are currently two new designs already in progress: 55/110 GHz and 110/220 GHz for use in a 690 GHz heterodyne tipping radiometer [8]. These designs will become the first iteration of the MMA designs. Figure 7.2.2 shows a sketch of the 110/220 GHz block. Future iterations will be concerned with increasing the output power of the doublers and increasing the operational bandwidth as well as making the designs easier to fabricate. Designs using discrete planar varactors are limited to about 250 GHz because the size of the chip package becomes electrically large and therefore the multiplier circuit becomes exceedingly more difficult to tune properly over a wide bandwidth.

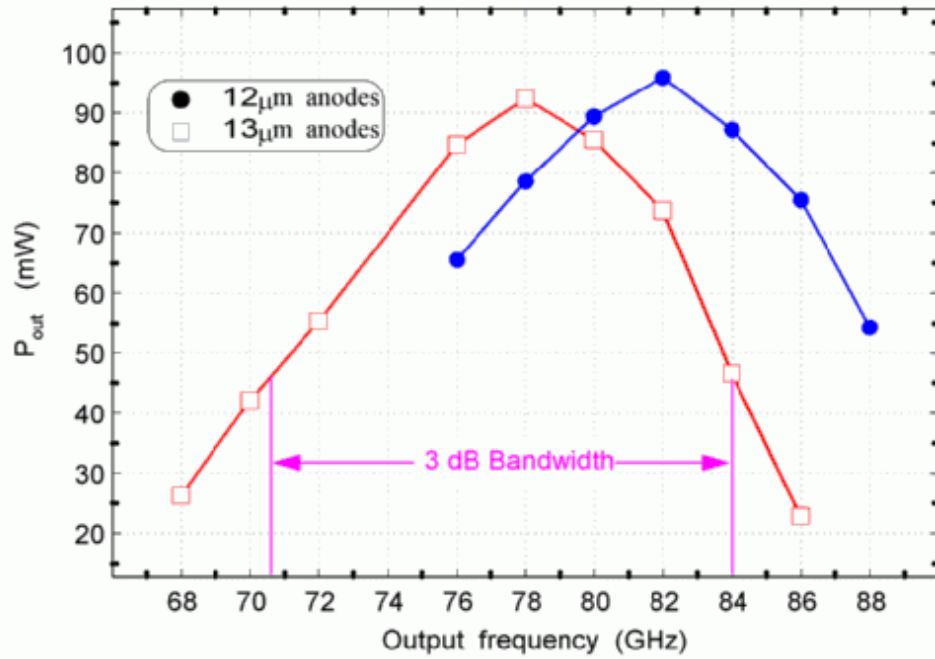

Click to zoom

Figure 7.2.1 Measured output power as a function of frequency for the 40/80 GHz doubler [6].

A)

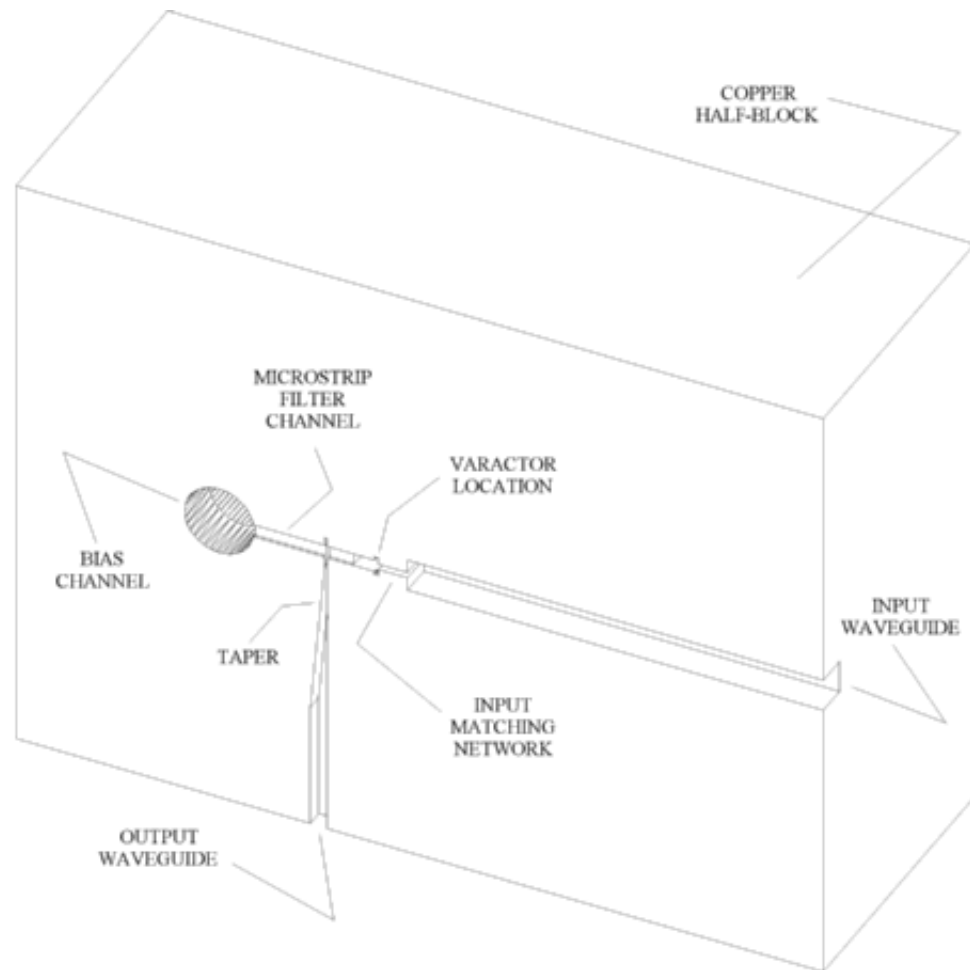

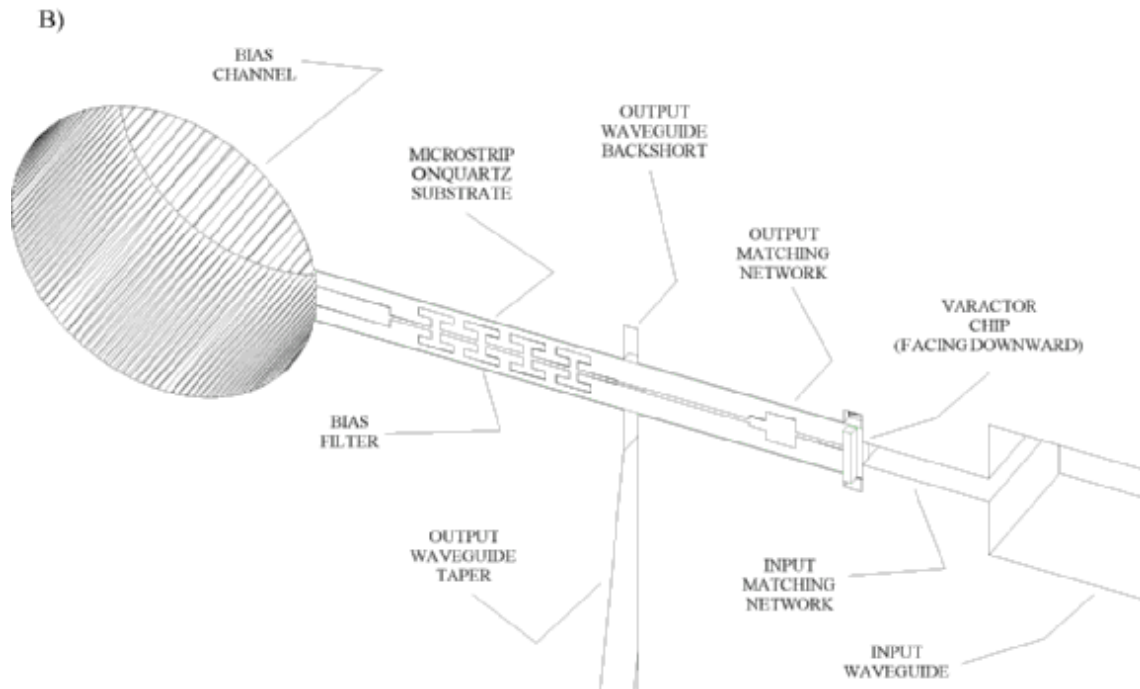

Click on images to zoom

Figure 7.2.2 Sketch of 110/220 GHz doubler.
A) one-half of the split block design and B) details of microstrip circuitry.

The second development area will focus on the doublers and triplers needed to extend the PLL LO up to 700 GHz. Because of the short wavelengths involved, these designs will require some level of circuit integration (MMIC). Due to the high development costs of MMICs, sharing ideas and designs between groups is prudent and so we are exploring areas of common need among projects such as the MMA, FIRST/HIFI, etc. Recently, a collaboration was formed between the

NRAO-CDL and NASA-JPL for MMIC multiplier development, where our experience in multiplier circuit design and electromagnetic simulation will be coupled with the MMIC fabrication experience of JPL. Two initial designs are currently underway: a 200/400 GHz balanced doubler and a 220/660 GHz balanced tripler.

The third development area will concentrate on the two phase-locked LO systems used to drive the frequency multipliers. A block diagram of the RF oscillator is shown in Fig. 7.2.3. The 100 mW, 60-90 GHz oscillator consists of a 10-15 GHz YTO followed by a doubler to 20-30 GHz, a 10 dB power amplifier, a tripler to 60-90 GHz, and a second 10 dB power amplifier. The 80-120 GHz oscillator consists of a YTO, doubler, and power amplifier to 20-30 GHz as in the previous case, but here it is followed by a doubler to 40-60 GHz, a 9 dB power amplifier, and a high power doubler. Both systems will require appropriate interstage filters and isolators. The bandwidth of the phase-locked sources may be limited by the availability of power amplifiers since research groups requiring such amplifiers are forced to share designs due to high development costs. It is not clear at this time how the MMA LO will be affected by amplifier availability.

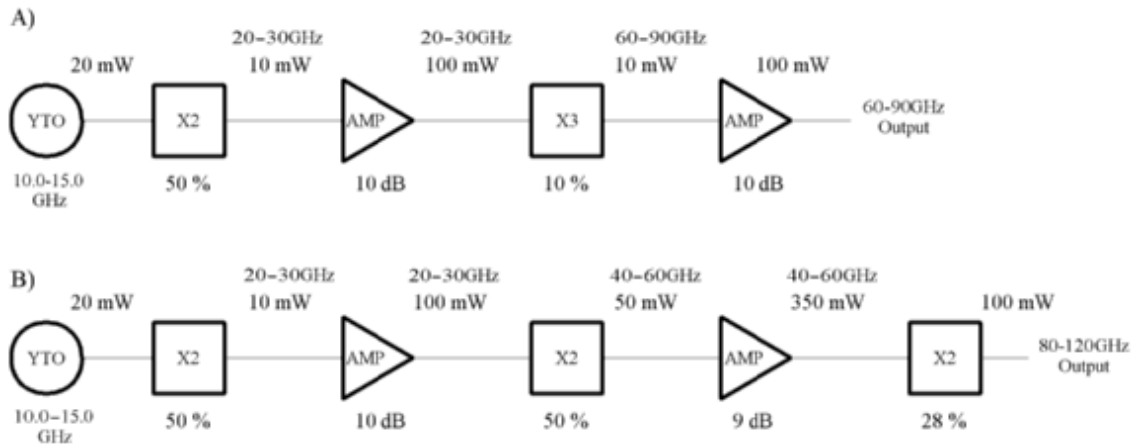

Click to zoom

**Figure 7.2.3 All-electronic oscillator for
A) 60-90 GHz and B) 80-120 GHz.**

Understanding the noise contribution of the various approaches to generating LO power at 100 GHz is important. The type of LO system that will meet the array noise performance specifications will have an enormous impact on the entire MMA system design, both in the degree of complexity and the overall cost. Furthermore, based on the measurements, a decision will be made regarding the highest frequency that can be included within the phase-locked loop; this decision will impact millimeter-wave harmonic mixers.

To study PM noise, a standard phase noise measurement system will be constructed. This system will be based on the complete HP phase noise measurement system, including the necessary mixers to translate the 100 GHz signals down to the operating range of the instrument. A stable reference oscillator and distribution system should also be purchased. For AM noise studies, a 100 GHz SIS mixer, which is currently available at the NRAO-CDL, may be used. However, a balanced Schottky system, dedicated specifically for AM noise measurement, would be quite useful, since the system will not require cooling and the balanced nature of the design results in the LO noise directed to a separate IF port for ease of measurement. Two YIG-based phase-locked oscillator/ amplifier/ multiplier chains as well as phase-locked Gunn-effect oscillators will be compared on the basis of both AM and PM noise.

Finally, the fourth development area will center on the "functional prototype" which is defined here as a complete LO system, ready for installation into the prototype MMA antenna system. We will build upon the breadboard version developed earlier; various modifications will be done to provide for locking to the distributed microwave reference signal, insure compatibility with fringe rotation functions, provide proper frequency control, and provide power leveling control. Size reduction and modular packaging will also be performed. Close coordination with the front-end, system, and control groups will be essential.

REFERENCES

1. Bradley, R.F. "Wide Bandwidth, YIG-Based Sources and Modern Frequency Multipliers for the MMA Local Oscillator System," NRAO MMA Memo No. _____, May, 1998.
2. S-K Pan, Private Communication.
3. D. Woody, M. Holdaway, O. Lay, C. Masson, F. Owen, R. Plambeck, S. Radford, and E. Sutton, "The MDC phase calibration working group report," NRAO MMA Memo 144 (<http://www.cv.nrao.edu>), Oct. 3, 1995.

4. P. Napier and J. West, "High Altitude Medical and Operations Problems and Solutions for the Millimeter Array," Proc. SPIE, 3349, 1998.
5. R. F. Bradley and R. J. Mattauch, "Planar monolithic Schottky varactor diode millimeter-wave frequency multipliers," Technical Report RL-TR-92-187, Rome Laboratory, Air Force Systems Command, Griffiss Air Force Base, NY, June 1992.
6. D. W. Porterfield, T. W. Crowe, R. F. Bradley, and N. R. Erickson, "A high-power, fixed-tuned, millimeter-wave balanced frequency doubler," submitted to IEEE Trans. on Microwave Theory and Techniques, Jan. 1998.
7. N. Erickson, "Wideband High Efficiency Planar Diode Doublers," Ninth International Symposium on Space Terahertz Technology," Pasadena, CA March, 1998.
8. R. F. Bradley and S-K. Pan, "690 GHz Tipping Radiometer: A Design Survey," NRAO Electronics Division Technical Note 171, Aug 28, 1995.