

LO-REFERENCE, IF and FIBER OPTICS TRANSMISSION

Bill Brundage
Draft, Last revised 1998-November-05

Revision History:

1998-Nov-05: Major update of everything.

Summary

The MMA local oscillator reference (LO-Ref), consisting of a number of frequencies, will be generated in the electronics building and distributed via coaxial cable to equipment in the building and via fiber optics to the receivers in each of the antennas. It will include microwave round-trip phase measurement of the LO-Ref to each antenna (unless a photonic phase *correction* scheme is proven and adopted). The intermediate frequency (IF) signals from the active receiver in each antenna will be processed in each antenna and transmitted via fiber optics (FO) to the electronics building for further processing and input to the samplers. Currently MMA design and development (D&D) has adopted analog fiber optic transmission of the IF signals, but sampling at the antennas and digital fiber optic transmission will be an option. Fiber optic cables will transmit the LO-Ref, round-trip phase-meter, IF and monitor-control signals between the electronics building and each antenna. Tables 9.1, 9.2 and 9.3 list the principal performance requirements for the LO-Ref, IF and FO-transmission, respectively.

Table 9.1 Principal performance requirements of LO-Reference system

LO-Ref max frequency error at antenna and at building	[1 part in 10^{12}] averaged over [10] seconds
LO-Ref max phase noise at 10 GHz at each antenna	[1] degree rms over [10] seconds
LO-Ref phase coherency, max error ($f \oplus f + Df \oplus f$)	[TBD] ^o at 10 GHz at each antenna
LO-Ref fringe rotation range	+/- 0 to [TBD] Hz in steps of [TBD] milliHz
LO-Ref phase switching, max error	90 ^o and 180 ^o , +/- [0.5] ^o
LO-Ref timing frequencies for phase switching, amplitude calibrations and phase calibrations	[TBD] Hz, [TBD] Hz, [TBD] Hz

Table 9.2 Principal performance requirements of IF system

IF input frequency range, each of 2 polarizations from any one front end	USB and LSB at 4-8 GHz and at 4-12 GHz
IF outputs from analog baseband filter (BBF), if D&D implements BBF	8 outputs per antenna, each tunable to any frequency within IF input spectrum via LO-Ref PLOs and synthesizers
IF outputs from baseband converter (BBC) to sampler, if D&D implements digital filter (DF)	8 outputs per antenna, each tunable to any frequency within IF input spectrum via LO-Ref PLOs and synthesizers
IF amplitude variation from inputs-to-outputs in any 2 GHz bandwidth over time	< [2] dB peak-to-peak / 2 GHz / [60] minutes
IF group delay variation from inputs to outputs in any 1 GHz bandwidth over time	< [TBD] nanosec / GHz / [60] minutes

Table 9.3 Principal performance requirements of FO Transmission system

FO transmission of LO-Ref and Round-Trip Phase	Amplitude and phase stability sufficient for LO specs; [0.5 ps] max variation in delay on 25 km of fiber over [60] minutes
FO transmission of IF	Amplitude and phase stability sufficient for IF specs; [1 ps] max IF dispersion across any 2 GHz bandwidth on 25 km of fiber over [60] minutes
FO transmission of Monitor/Control (M/C)	Two-way M/C up to [5] Mbit/sec at each antenna

The D&D phase will produce detailed designs to the component level, will include the building of certain bench-prototypes to minimize risks in design or cost, and will make several decisions on design approaches. Table 9.4 lists the principle milestones.

Table 9.4 Principal milestones for D&D work on LO-Reference, IF and FO transmission

Decision: FIR digital filter (DF) or analog baseband filter (BBF)	December, 1998
Decision: analog or digital IF transmission on fiber	March, 1999
Decision: standard or dispersion shifted fiber (1310 or 1550 nm)	March, 1999
Preliminary Design Review: IF and FO systems	April, 1999
Preliminary Design Review: LO-Ref system	June, 1999
Critical Design Review: IF and FO systems	March, 2000
Decision: Multiplier-LO or Photonic-LO	June, 2000
Critical Design Review: LO system	June, 2000
Deliver bench-prototype IF system	January, 2001
Deliver bench-prototype FO system	January, 2001
Deliver bench-prototype LO-Ref system	January, 2001

9.1 Introduction

This Chapter 9 presents the current understanding of the performance requirements for the MMA LO-Reference, IF and Fiber Optics transmission systems. It also describes the current specifications and design concepts which will satisfy these requirements. Figure 9.1 shows the basic block diagram and major interfaces of the three systems.

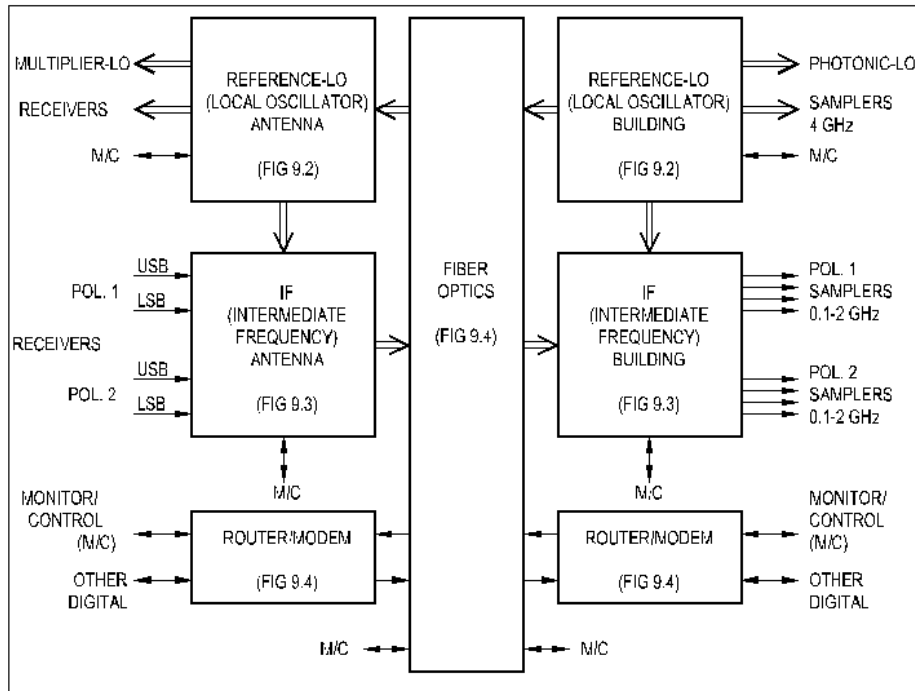

Figure 9.1: Reference-LO IF and FO Systems

9.2 Specifications

MMA Project Book Chapter 8, System Design Overview, gives the basic performance requirements. Table 9.1 lists the principal performance requirements. This section describes specifications based on the performance requirements and the system blocks shown in Figure 9.1. Other specifications to-be-determined [TBD] will appear in the future in this Chapter, and some in Project Book Chapter 8.

For all three systems, *electromagnetic compatibility (EMC)* specifications for radiated and conducted emissions are minimum generation of and susceptibility to internal and local RFI, and maximum immunity to external RFI in terms of good engineering practice by shielding and filtering to minimize egress and ingress by radiation and conduction. Future D&D may impose limits by measurement of radiated emissions in terms of effective isotropic radiated power (EIRP) from an enclosure or package including power cables.

9.2.1 LO-Reference, Specifications

All output frequencies are phase coherent relative to the fundamental reference frequency of [100] MHz ($[+/-1 \text{ part in } 10^{12}]$) produced by a hydrogen maser or a rubidium backup, which are located at the Electronics Building. Other specification parameters, such as power levels, phase noise levels and spurious levels are [TBD]. See Tables 9.1, 9.5, 9.6 and Figure 9.1.

Spurious frequencies in any LO-Ref output will be $> [TBD] \text{ dBc}$ below LO signal power.

Define LO-Ref *signal-to-noise-ratio* (SNR_x) at LO-Ref system location x as ratio in dBc/Hz of power in LO-Ref frequency to noise power in 1 Hz bandwidth in spectral sidebands at offset > [1 kHz].

Define LO-Ref *headroom* ($H2_x$) at LO-Ref system location x as the ratio of available second-order-intercept power (IP2) to the LO signal power (P_x) at location x. The ratio of LO power to second harmonic power equals the ratio of IP2 to LO power, which is H2. Thus for example, the second harmonic power will be H2 below the LO signal power. Thus $H2_x$ should exceed [40] dB to provide a reasonably low second harmonic (*spurious*) level [and additional phase noise].

Components, modules, bins and racks will have *supply voltage coefficients, temperature coefficients, thermal time constants and temperature environments* sufficient for the system specifications. D&D assumes temperature of ambient air forced into racks is 16 ± 2 C at 420 Torr (5000 m altitude), enthalpy of [TBD] and mass flow of [TBD].

9.2.1.1 LO-Ref in the Electronics Building, Specifications

Table 9.5 Specifications for the LO-Ref in the Electronics Building

Function	Frequencies (GHz)	Power (dBm)	P spur (dBc)	F noise deg rms	SNR dBc/Hz	Qty Out	Inputs; Outputs
Frequency standard: Hydrogen maser (+ rubidium backup)	[0.1][\pm 1part 10^{12}] [0.01][\pm 1part 10^{12}]	+10	[TBD]	[TBD]	[TBD]	1	Out: generator
Generation and distribution	1 Hz, 1 MHz, 1, 10, [TBD] phase switch, [TBD] calibration	+10	[TBD]	[TBD]	[TBD]	1	In: freq std; Out: (7) PLOs, 8xNant 3.2-5.2GHz+fringe synth, R-T Phase Meter, LO-Photonic, FO-Tx
Round-trip phase meter	10 GHz	In: 0				1	In: 10GHz Dist & FO-Rx; Out: phase diff \pm [0.1]deg via M/C

PLOs and Distributors	0.375, 1.5 4 8, 10, 12, 14	+10 +10 +10	[TBD] [TBD] [TBD]	[TBD] [TBD] [TBD]	[TBD] [TBD] [TBD]	N N N	Out: N ant racks & IF BBFs Out: N ant racks & Samplers Out: N ant racks & IF De-muxs
3.2-5.2 GHz & Fringe Rotation synthesizer	3.2-5.2 in steps of [TBD] milliHz, [coherent f® D f® f]	+10	[TBD]	[TBD]	[TBD]	8xN ant	Out: IF BBC
f1 10-15 GHz Synthesizer (LO-Photonic)	10-15 in steps of [TBD] MHz	+10	[TBD]	[TBD]	[TBD]	1	Out: LO-Photonic
f2 100 MHz Synthesizer (LO-Photonic)	[99-101] MHz in steps of [TBD] Hz	+10	[TBD]	[TBD]	[TBD]	1	In: from Fringe Rot & Phase Sw Gen; Out: LO-Photonic
Fringe Rotation & Phase Switch Generator (LO-Photonic)	[TBD]	[TBD]	[TBD]	[TBD]	[TBD]	2	In: Phase sw, 1Hz, 1MHz from distr, fringe rot freq from M/C; Out: [freq] & phase switch to f2 synth & correlator

9.2.1.2 Antenna LO-Ref, Specifications

Table 9.6 Specifications for the LO-Ref in each Antenna

Function	Frequencies (GHz)	Power (dBm)	P spur (dBc)	F noise deg rms	SNR dBc/Hz	Qty Out	Inputs; Outputs
Distributor and PLOs	1 Hz, 1 MHz, 1, 10, 16, . 26, . [TBD] phase switch, [TBD] calibration	..+10 ..+10 +10 [TBD] [TBD]	.. [TBD] ... [TBD] [TBD]	.. [TBD] .. [TBD] [TBD]	.. [TBD] .. [TBD] [TBD]	..2 ..2 [3] 1 [10]	In: FO Rx; Out: LO-Multiplier, 10 GHz to FO Tx R-T Phase ... Out: IF Multiplexers Out: HFET front ends . Out: LO-Multiplier .. Out: Front end ampl & phase cals
VCXO Cleanup Loop (LO-Multiplier)	[TBD]	+10	[TBD]	[TBD]	[TBD]	1	In: Distrib; Out: 10-15 GHz Synth
10-15 GHz Synthesizer (LO-Multiplier)	10-15 GHz in [TBD] MHz steps	+10	[TBD]	[TBD]	[TBD]	[10]	In: VCXO; Out: LO-Multiplier drivers
Fringe-rotation & Phase-switch generator (LO-Mult)	[TBD] & [TBD] Hz	[TBD]				[10]	In: Distrib; Out: LO-Multiplier drivers

9.2.2 IF System, Specifications

The IF system takes the 2-polarization upper and lower sideband outputs (total of 4) in the 4-12 GHz range from the receivers on each antenna and delivers 4 outputs per polarization, each of specified frequency ranges, to the digital samplers for each antenna. See Table 9.2 and Figure 9.1.

If D&D implements analog baseband filters (BBF), the IF system outputs selected bandwidths to the digital samplers. If, instead, D&D implements digital baseband filters (DF), the IF system outputs 0.1-2 GHz to the digital samplers.

If D&D implements analog FO transmission of the IF, the IF processing at each antenna will be minimal for optimal cost and performance of the combined IF and FO systems. If D&D implements digital FO transmission, the entire analog IF system will be located in each antenna along with the digital samplers.

Table 9.2 specifies *input to output amplitude variation* in any 2 GHz bandwidth as $< [2]$ dB peak-to-peak over [60] minutes.

Define *normal IF signal noise spectral power (SPx) in the desired IF passband* at location x in units of dBm/GHz. At IF system input and output interfaces, SPx will have a nominally flat distribution across the passband.

Define *signal-to-noise-ratio (SNRx)* at IF system location x as the ratio of total system noise spectral power to the equivalent internal noise spectral power looking downstream. SNRx will be $> [30]$ dB at all IF locations.

All frequency conversions will have *image suppression (I)* $> [30]$ dB throughout the passband. Mixer image noise will be included in all designs.

Define IF *headroom (Hx)* at IF system location x as the ratio of available *third order-intercept power (IP3)* to the *normal total system noise power (Pn) - 20 dB* at location x. Typically, detrimental non-linear effects of gain compression and inter-modulation occur when the IF total power exceeds IP3 - [20] dB. For example, if H = 0 dB, then the power of the 3rd order intermodulation frequency will be $2 \times 20 \text{ dB} = 40$ dB below the lower powered of the two intermodulating frequencies. Hx will be $> [10]$ dB at all IF locations.

Define IF *Group Delay Variation (D GD/D t)* as a time delay per unit frequency interval per unit of time in units of nanosec/GHz/60minutes from system input to system output. Table 9.2 specifies D GD/D t *from IF inputs to outputs* as $< [\text{TBD}]$ nanosec/GHz/[60] minutes. If D&D implements analog IF transmission over fiber, then the FO transmission is embedded in this specification. Note GD in terms of a measurement of phase vs frequency (via a vector network analyzer) is $\text{GD} = D F / (D f * 360^\circ)$.

Components, modules, bins and racks will have *supply voltage coefficients, temperature coefficients, thermal time constants and temperature environments* sufficient for the system specifications. D&D assumes temperature of ambient air forced into racks is 16 ± 2 C at 420 Torr (5000 m altitude), enthalpy of [TBD] and mass flow of [TBD].

Table 9.7 Specifications for the IF System for each antenna

Function	Frequency (GHz)	SP (dBm/GHz)	BW (GHz)	Total Power (dBm)	Hdrm (dB)	Notes

Inputs from 1 front end, each of 2 polarizations, USB & LSB	4-8 4-12	[-36]	4	[-30]	[>20]	
Inputs from LO-Ref PLO	16			+10		For 2 IF-Multiplexers
Output to M/C of total power level for each of the 2 IF inputs per polarization from 1 front end	4-8, 8-12, 4-12					Deviation from linear power < 1% from -3 dB to +7 dB relative to normal, digital resolution and stability < 0.2*rms noise, integration time [TBD] seconds
Inputs from LO-Ref PLOs	8, 10, 12, 14			+10		For 2 IF De-Multiplexers
Inputs (8) from LO-Ref 3.2-5.2 GHz & fringe rotation synthesizers	3.2-5.2			+10		For 8 baseband converters (BBC)
If D&D implements analog baseband filters (BBF), inputs from LO-Ref PLOs	0.375 1.5			+10 +10		For 8 baseband filters (BBF)
Inputs via M/C from 8 sampler state-counters to set output levels to each sampler						5 bit binary will provide 16 dB range in 0.5 dB steps [or 32 dB range in 1 dB steps]

If D&D implements analog BBFs, each BBF output to each of 8 samplers	Select 0.1-2, 1-2, 1-1.5, .250-.500, .250-.375, .0625-.125 or .0625-.09375	-3 0 +3	... 2 1 .5 .25 .175 .0875 .03125	Set via M/C in [1] dB steps at @ [0] dB	[>10]	Tuned throughout any of the IF input bandwidths via the LO-Ref PLOs and 3.2-5.2 GHz & fringe rotation synthesizer / BBC
If D&D implements digital filters, each BBC output to a sampler	0.1-2			Set via M/C in [1] dB steps at @ [0] dB	[>10]	Tuned throughout any of the IF input bandwidths via the LO-Ref PLOs and 3.2-5.2 GHz & fringe rotation synthesizer / BBC
Outputs via M/C of IF total power delivered to each of 8 samplers						Deviation from linear power < 1% from -3 dB to +7 dB relative to normal, digital resolution and stability < 0.2*rms noise, integration time [TBD] seconds

9.2.3 FO Transmission, Specifications

The fiber optic (FO) transmission system provides all of the communications links between each antenna and the electronics building. It carries all LO-Ref frequencies to each antenna and returns a LO-Ref 10 GHz for the round-trip phase meter via analog transmissions on 2 fibers, or alternatively on a single fiber using optical circulators. It carries the 2 IF channels for the 2 receiver polarizations from each antenna to the electronics building via 1 fiber using wavelength division multiplexing (WDM) and analog modulation. If D&D implements locating the samplers at the antennas, their outputs would be transmitted by digital modulation and WDM on 1 or 2 fibers. Components, modules, bins, racks and fibers will have **temperature coefficients, thermal time constants and temperature environments** sufficient for the system specifications. D&D assumes temperature of ambient air forced into racks is 16 ± 2 C at 420 Torr (5000 m altitude), enthalpy of [TBD] and mass flow of [TBD]. D&D also assumes in-ground fibers will

be buried >0.5 m below the surface where the thermal rate of change < [TBD] C / hour.

9.2.3.1 FO Transmission of LO-Ref, Specifications

Inputs: All LO-Ref frequencies (1 Hz to 10 GHz) from the building LO-Ref distributor, per Table 9.5

Modulation: Analog, external modulator for minimal frequency modulation of the laser.

Fiber transmission: WDM onto single fiber to each antenna, minimum number of wavelengths necessary to meet performance specifications.

Outputs: All LO-Ref frequencies (1 Hz to 10 GHz) to the antenna LO-Ref distributor, per Table 9.6.

9.2.3.2 FO Transmission of LO-Ref Round Trip Phase, Specifications

Input: 10 GHz from antenna LO-Ref distributor, per Table 9.6.

Modulation: Analog, external modulator for minimal frequency modulation of the laser.

Fiber transmission: Single fiber from each antenna, or alternatively same fiber as LO-Ref via optical circulators without degrading transmission of LO-Ref to each antenna.

Output: 10 GHz to LO-Ref round-trip-phase meter, per Table 9.6.

9.2.3.4 FO Transmission of IF from Antennas to Electronics Building, Specifications

Inputs: Analog from 2 IF outputs of 2 receiver polarizations, 4-12 GHz, or 4 digital inputs to the FO transmitter at 8 Gb/s each, per Table 9.7.

Modulation: Analog or digital via external modulators for minimal frequency modulation of the laser.

Fiber transmission: WDM onto single fiber to each antenna, minimum number of wavelengths necessary to meet performance specifications.

Outputs: One 4-12 GHz IF for each of 2 receiver polarizations, if analog. 4 digital outputs at 8 Gb/s each, per Table 9.7.

9.2.3.5 FO Transmission of Monitor-Control, Specifications

Inputs at Antenna and at Electronics Building: serial bit stream up to [1 Mb/s] for monitor-control bus and other digital functions from router/modem. Logic levels and maximum timing latency [TBD].

Fiber transmission: Single fiber in both directions via optical circulators.

Outputs at Antenna and at Electronics Building: serial bit stream up to [1 Mb/s] for monitor-control bus and other digital functions to router/modem. Logic levels and maximum timing latency [TBD].

9.2.2.6 FO Fiber, Cable and Interfaces, Specifications

Single mode fiber can be either standard fiber with zero dispersion at 1310 nm or dispersion shifted fiber with zero dispersion at 1550 nm. Whichever D&D implements should provide the optimum combination of system cost and performance of the LO-Ref and IF systems. Fibers in building, ground and on antennas should be in an environment with a temperature rate of change sufficiently low for overall LO-Ref and IF specifications. Cables of fibers, whether tight buffer, loose tube or blown-through-conduit, should have a 30 year lifetime for their environment in building, junction boxes, antenna attachment, movement, temperature, ground, sunlight and weather. Loss and reflection of all interfaces such as splices and connectors will be adequately low and stable over a 30 year lifetime. D&D assumes un-equal lengths (<25 km) of fiber between the electronics building and the various antenna stations.

9.3 Current Design

MMA Project Book Chapter 8, System Design Overview, gives the basic design for the three systems. MMA Memo #190, A System Design for the MMA, gives some additional detail. Figure 9.1 shows the basic block diagram and major interfaces of the three systems and separates the subsystems located at the electronics building and each antenna.

9.3.1 Reference LO, Current Design

Figure 9.2 shows the diagram of the major blocks of the reference local oscillator (LO-Ref) system and separates the subsystems located at the electronics building and each antenna.

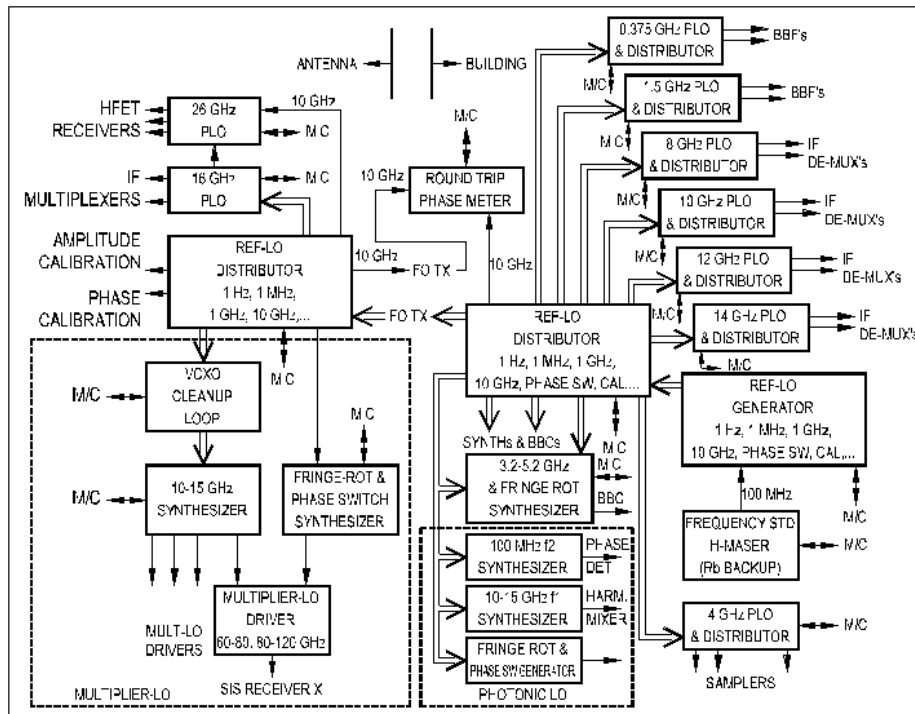

Figure 9.2: Reference-LO System (Local Oscillator)

9.3.1.1 Frequency Standard: Consists of a hydrogen maser with [100] MHz output and a rubidium source as back-up.

9.3.1.2 LO-Ref Generator: Consists of frequency dividers, multipliers and phase-lock-loops (PLO) which take the input [100] MHz frequency standard to generate the output 1 Hz, 1 MHz, 1 GHz, 10 GHz, phase switch and calibration frequencies for the array. Other frequencies may become necessary as D&D progresses.

9.3.1.3 LO-Ref Distributor (building): Consists of power dividers and high-reverse-isolation buffer amplifiers to distribute the reference frequencies to the FO LO-Ref transmitter and to the Photonic-LO synthesizers f1 (10-15 GHz), f2 (100 MHz), fringe rotation and phase switch. If D&D implements analog FO transmission of IF, then additional circuits will distribute appropriate reference frequencies to the 7 phase-lock-oscillators (PLO) which generate 0.375, 1.5, 4, 8, 10, 12 and 14 GHz; also additional circuits will distribute appropriate reference frequencies to each of the [N] antenna racks. Each antenna rack will have additional reference frequency distribution circuits to feed 8 synthesizers (3.2-5.2 GHz with fringe rotation).

9.3.1.4 Phase-locked-oscillators (PLO): Seven PLOs, with appropriate frequency inputs from the LO-Ref distributor, generate fixed output frequencies which are distributed to [N] antenna racks. Each antenna rack will have additional reference frequency distribution circuits to feed appropriate frequencies to 2 IF De-muxs, 8 baseband converters (BBC), 8 BBF and 8 digital samplers. The seven PLO frequencies and their destinations at each antenna rack are:

PLO frequency	Destination at each antenna rack
0.375 GHz	8 BBF
1.5 GHz	8 BBF
4 GHz	8 Digital Samplers
8 GHz	2 IF De-multiplexers
10 GHz	2 IF De-multiplexers
12 GHz	2 IF De-multiplexers
14 GHz	2 IF De-multiplexers

If D&D implements digital IF transmission, then either N antenna sets of these PLOs would be necessary, or these PLO frequencies would be sent on fiber to all antennas. The cost tradeoff would be between additional PLOs and additional FO lasers, although several frequencies might be modulated onto one laser.

9.3.1.5 Synthesizer 3.2-5.2 GHz with fringe rotation: Each of [N] antenna racks in the electronics building will contain 8 of these synthesizers. If D&D implements digital IF transmission, then 8 of these synthesizers would be located in each of [N] antennas. Inputs are appropriate reference frequencies from the LO-Ref Distributor. Each has one output which goes to the associated IF BBC.

9.3.1.6 Round-trip phase meter (building): Each of [N] antenna racks in the electronics building will contain 1 of these phase meters. Inputs at 10 GHz from the LO-Ref distributor and from the FO antenna return are compared in phase and the difference phase angle is output to the on-line control system via the monitor/control bus.

9.3.1.7 Synthesizer f1 10-15 GHz for Photonic-LO (building): Only if D&D implements the Photonic-LO, each of [N] antenna racks will contain 1 of these synthesizers to drive one harmonic mixer. Inputs are appropriate frequencies from the LO-Ref distributor. See Figure 6 of MMA Memo 190.

9.3.1.8 Synthesizer f2 100 MHz for Photonic-LO (building): Only if D&D implements the Photonic-LO, each of [N] antenna racks will contain 1 of these synthesizers to drive the reference input to a phase detector. Inputs are appropriate frequencies from the LO-Ref distributor and from the fringe-rotation/phase-switch generator. See Figure 6 of MMA Memo 190.

9.3.1.9 Fringe-rotation/phase-switch generator for Photonic-LO (building): Only if D&D implements the Photonic-LO, each of [N] antenna racks will contain 1 of these generators to drive the reference input to a phase detector. Inputs are appropriate frequencies from the LO-Ref distributor and from the monitor/control system. See Figure 6 of MMA Memo 190.

9.3.1.10 Antenna LO-Ref distributor: The FO LO-Ref receiver outputs the reference frequencies. The distributor outputs appropriate frequencies to the FO transmitter of round-trip phase, to the 16 and 26 GHz PLOs, amplitude and phase calibration systems, and (if D&D implements it) to the Multiplier-LO.

9.3.1.11 PLO 16 GHz (antenna): This PLO inputs appropriate frequencies from the antenna LO-Ref distributor and outputs 16 GHz to the 2 IF multiplexers and the 26 GHz PLO in each antenna.

9.3.1.12 PLO 26 GHz (antenna): This PLO inputs 10 GHz from the LO-Ref distributor and 16 GHz from the 16 GHz PLO. It outputs 26 GHz to [M] HFET receivers.

9.3.1.13 VCXO cleanup loop for Multiplier-LO (antenna): Only if D&D implements the Multiplier-LO, each antenna will have one VCXO module to input appropriate frequencies from the LO-Ref distributor and output appropriate frequencies with very low phase noise to [X] 10-15 GHz synthesizers for [X] front ends. See Figure 5 in MMA Memo 190.

9.3.1.14 Synthesizer 10-15 GHz for Multiplier-LO (antenna): Only if D&D implements the Multiplier-LO, each antenna will have [X] 10-15 GHz synthesizers for [X] front ends. Inputs will be from the VCXO module and output will go to the associated Multiplier-LO Driver. See Figure 5 in MMA Memo 190.

9.3.1.15 Fringe-rotation and phase-switch generator for Multiplier-LO (antenna): Only if D&D implements the Multiplier-LO, each antenna will have [X] of these generators for the Multiplier-LO Driver for each of the [X] front ends. Inputs will be appropriate frequencies from the LO-Ref distributor and from the monitor/control bus. Outputs will be to the phased locked loop in a Multiplier-LO Driver. See Figure 5 in MMA Memo 190.

9.3.2 IF System, Current Design

Figure 9.3 shows the diagram of the major blocks of the (intermediate frequency) IF system. It separates the electronics building and antenna subsystems for analog FO transmission and for digital FO transmission.

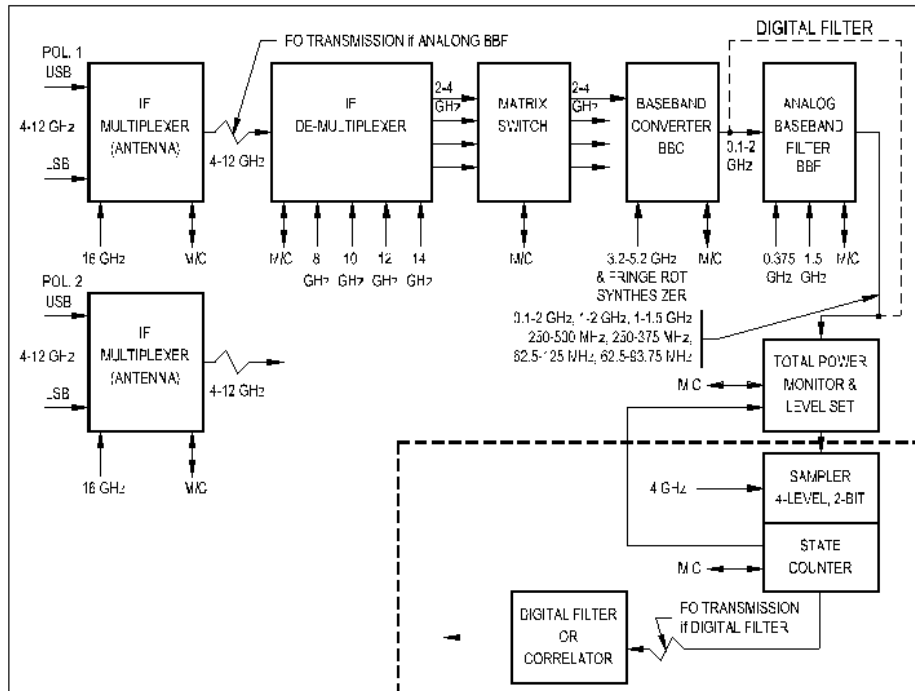

Figure 9.3: IF System (Intermediate Frequency)

9.3.2.1 IF Multiplexer (antenna): Each antenna contains 2 IF Multiplexers, one for each polarization from one of the front ends. Each IF multiplexer has 2 IF inputs from one of the front ends, upper sideband (USB) and lower sideband (LSB). The frequency range of each IF input is either 4-8 GHz or 4-12 GHz, depending on which front end is connected. A set of switches, power dividers, power combiners, filters, amplifiers, gain/phase equalizers and a frequency up-converter allow the following combinations of inputs and outputs to be selected:

SELECT	INPUT	OUTPUT
1	USB, 4-12 GHz	4-12 GHz
2	USB, 4-8 GHz	4-8 GHz
	LSB, 4-8 GHz	8-12 GHz
3	LSB, 4-12 GHz	4-12 GHz

The output goes to the FO IF transmitter for transmission via fiber to the electronics building. The frequency up-converter uses a 16 GHz input from a PLO of the LO-Ref. Four total power detectors, one in each input path, provide data to the on-line system via the monitor/control bus. The M/C bus controls the selector. Figure 2 in Chapter 8 shows a block diagram of the 2 IF multiplexers in each antenna.

9.3.2.2 IF De-multiplexer (building): Each of [N] antenna racks in the electronics building contains 2 IF De-multiplexers, one for each receiver polarization. The single input is one of the 4-12 GHz IFs from the FO IF receiver. A 4-way power splitter and a set of filters, amplifiers, gain/phase equalizers and frequency down-converters provide 4 outputs of 2-4 GHz each, derived from the input frequency bands of 4-6, 6-8, 8-10 and 10-12 GHz. The down-converters use 8, 10, 12 and 14 GHz inputs from PLOs of the LO-Ref system. Outputs go to a IF matrix switch. Figure 3 in Chapter 8 shows a block diagram of a IF De-multiplexer.

9.3.2.3 IF Matrix Switch (building): Each of [N] antenna racks in the electronics building contains 2 IF matrix switches, one for each receiver polarization. Each matrix switch connects any of the 4 outputs (2-4 GHz) from the IF De-multiplexer to any of 4 BBCs in any combination, including any one input to all 4 BBCs. M/C bus provides control of selections.

9.3.2.4 IF Baseband Converter (BBC) (building): Each polarization has 4 BBCs receiving input from the IF matrix switch.; total of 8 BBCs per antenna.

9.3.2.5 IF Baseband Filter (BBF) (building): If D&D implements analog baseband filtering rather than digital filtering (DF), each BBC outputs 0.1-2 GHz to a BBF (8 per antenna).

9.3.2.6 IF Total Power Monitor & Level Set:

9.3.3 FO Distribution, Current Design

Figure 9.4 shows the diagram of the major blocks of the (fiber optic) FO system.

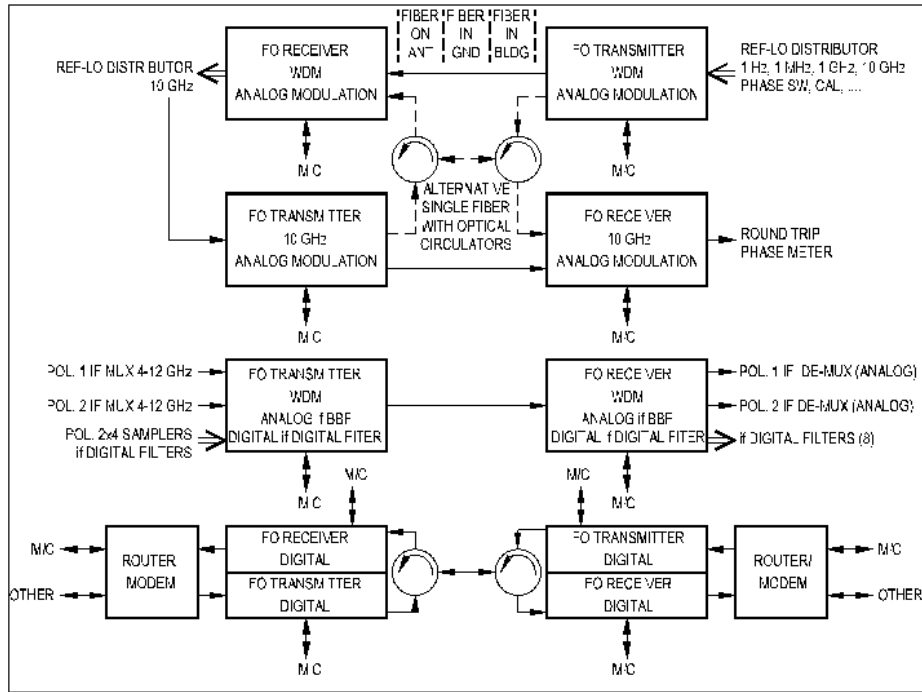

Figure 9.4: FO System (Fiber Optic)

Single mode fiber with zero dispersion at 1310 nm costs about 0.67 that of shifted fiber with zero dispersion at 1550 nm.

9.4 Construction Plans

9.4.1 Reference LO

9.4.2 IF

9.4.4 FO Distribution

9.5 Test and Integration Plans

9.5.1 Reference LO

9.5.2 IF

9.5.4 FO Distribution

9.6 References

To be completed ...
